



# *Sacred Heart Canossian School*

## 嘉諾撒聖心學校

優質教育基金 — 主題網絡計劃  
「小小科藝創建師」學生工作坊活動分享

# Contents

01

簡易樂器製作

02

電子迷宮

The background features a light gray gradient with several watercolor-style elements: a large orange circle at the top center containing the number '01', a yellow vertical rectangle on the left, a blue rectangle and a red rectangle on the right, and a yellow circle and a red rectangle overlapping at the bottom left. Thin, dark blue lines curve across the page, and small black dots are scattered throughout.

01

# 學生工作坊：簡易樂器製作

# 簡易樂器製作~三年級

預備材料：

透明膠片

水松塞

飲管

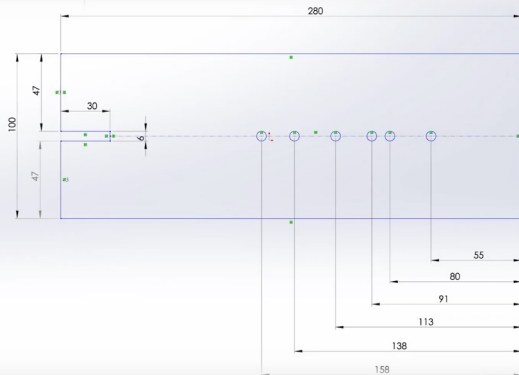

# 製作過程

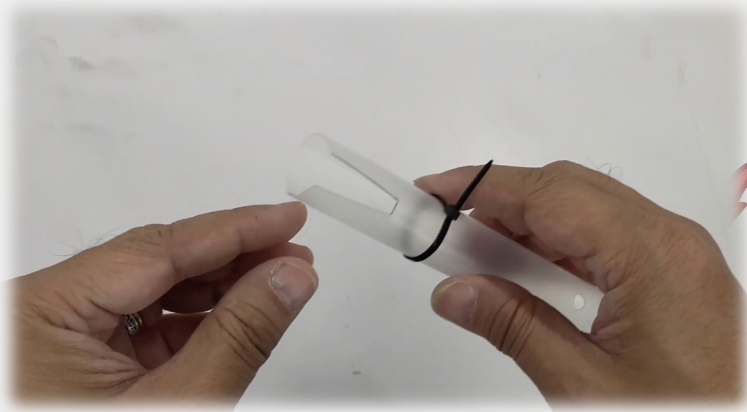
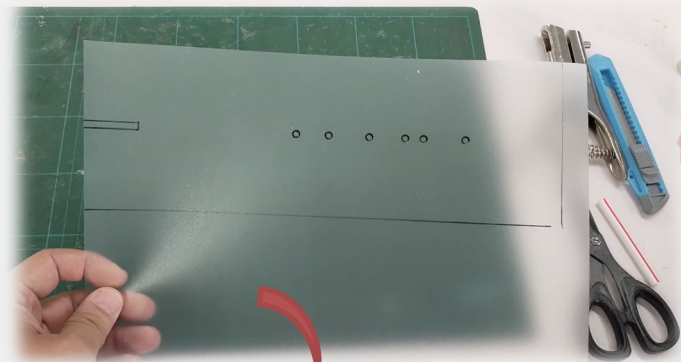
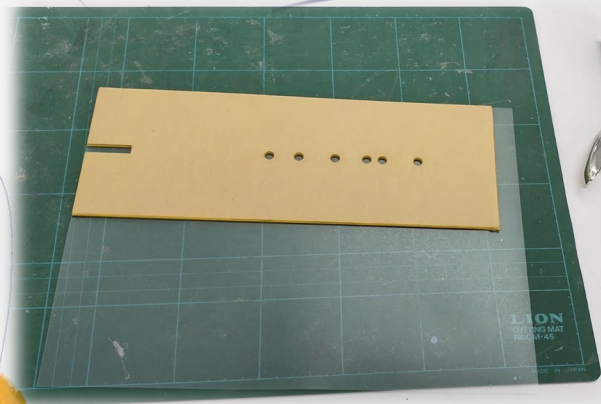

# 製作過程

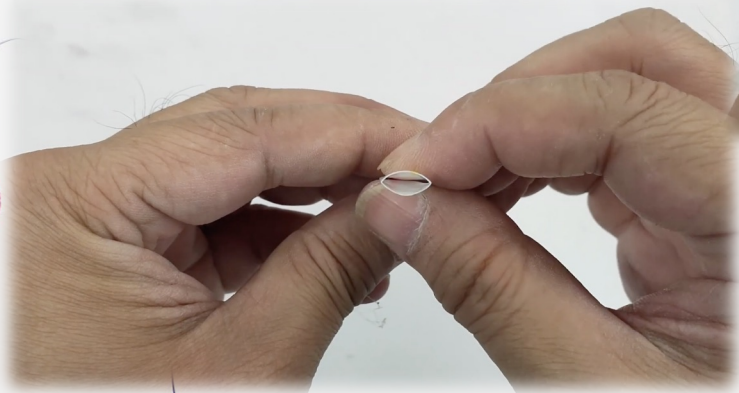

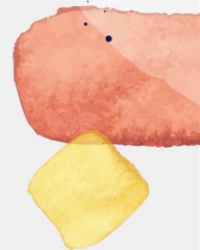

# 製成品





# 學生得著

- 認識材質對聲音的影響
- 比量尺寸、笛孔距離比例，學會調試音色及音準
- 了解聲音的產生及樂器發出聲響的原理
- 結合科學、技術、數學、視藝等以製作樂器
- 提高學生對STEAM的興趣
- 提升解難能力
- 提升協作能力

# 教師得著

- 加強教師對教授STEM課程的掌握度
- 學會如何建構學生的科學概念，如笛子的形狀材質對聲音的影響
- 引導學生製作笛子時探索不同的原理及概念
- 過程中觀察學生的表現，掌握學生的認知和能力，以調整課堂計劃



## 困難

- 一開始學生嘗試自己捲起膠片以製作笛管，惟學生難以自行完成
- 疫情關係，未能在課堂上吹奏，故難以在課堂中調較音色及音準

## 解決方法

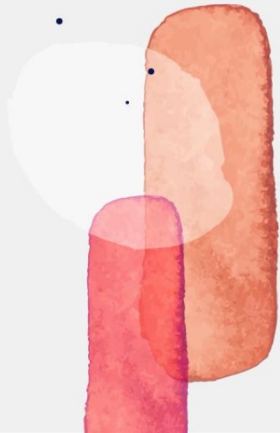
- 學生兩人一組，一人捲起膠片，另一人貼上膠紙以定位
  - 學生回家吹奏，記下遇上的困難，回校後詢問老師
- 

02

# 電子迷宮

四年級

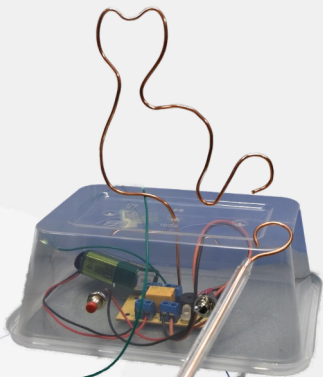

# 「電子迷宮」

- 「電子迷宮」的是一種以電為基礎的遊戲
- 玩家必須操控一個金屬指示物,使其通過一段迷宮,一旦該指示物觸碰到迷宮的牆壁,便會以聲音和燈光以示碰觸

# 學習目標

- 認識閉合電路
- 辨認正極和負極
- 導電體和絕緣體
- 電的光效應和聲效應

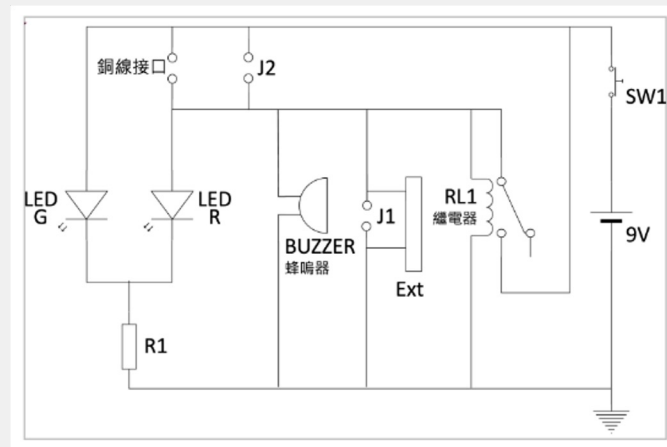
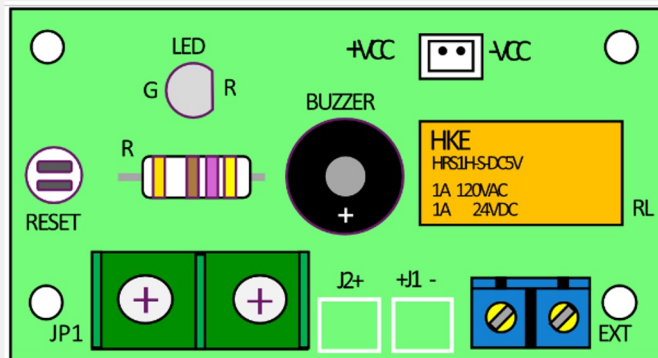

- 在製作前，學生先了解當中的科學原理



# 製作中

- 學生需要運用不同工具進行製作，例如：鉗子、螺絲起子
- 部分工序如：剪膠盒由於具危險性，由導師協助完成

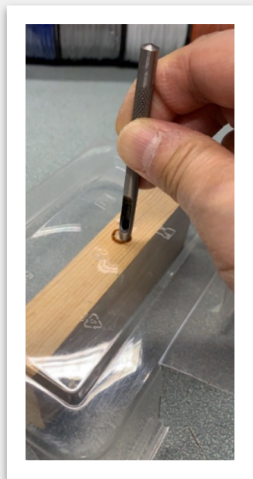
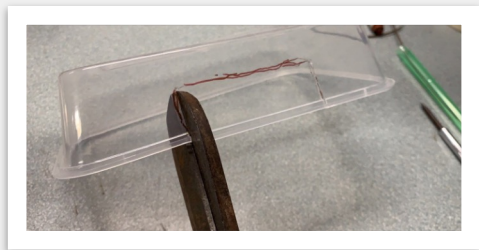



# 製成品



# 學生得著

- 提升對科學的興趣和運用工具的能力
- 訓練學生的專注和判斷力
- 認識電線和電池的接駁
- 發揮創意
- 完成電子迷宮

# 教師得著

- 透過觀課，學習帶領STEM課堂時要注意的細節
- 拓寬知識和經驗，例如:電子底板的功用
- 認識學生操作工具的安全指引
- 從中觀察學生的表現，了解學生的認知和能力

The image features a central, horizontal, yellow watercolor-style rectangle with a textured, slightly irregular edge. Inside this rectangle, the word "Thanks" is written in a black, cursive script font. Surrounding the central rectangle are several abstract, watercolor-style shapes in various colors: a reddish-orange rectangle on the top left, a dark blue shape on the middle left, a yellow diamond on the top right, a red rectangle on the middle right, and another reddish-orange rectangle on the bottom right. Thin, dark blue lines and small black dots are scattered across the light gray background, adding to the abstract, artistic feel of the composition.

*Thanks*